



INTRODUCTION

Congratulations !

You have just purchased one of the world's most sophisticated radar detectors.

Please read this instruction manual before installation. All instructions are necessary to achieve optimum use and trouble-free performance from your XT6000.

However, owning a radar-detector does not give you a license to speed. It is to be used as defence against unnecessary speeding offences caused by revenue-generating speed traps or occasional lapses of concentration on the part of the driver. Please drive safely.

XT6000 FEATURES

1. Power/Volume Control

Turns the unit ON/OFF and adjusts the volume level.

2. Band Identification LED's

Identifies whether K (yellow), Ka (green) or LASER band has been received.

3. Power ON LED indicator (P)

Indicates when power is being supplied to the unit.

4. CITY/Highway LED (C)

Indicates you are in the CITY-mode.

5. LED Signal Strength Meter

Consists of 4 LED's which inform you of the strength of the received signal.

6. Dark Button

Blank display with audible warning only.

7. Mute button

Activates mute mode, which silences the audio alarm only.

8. City/Highway button (CITY)

Decreases the unit sensitivity to radar signals when city mode is engaged.

9. Speaker

Ensures adequate volume.

10. Power Input Jack

Connect the DC Power cord here.

11. Receiving window

12. Power cord

This detector operates on a 12 Volts DC. Negative ground system only.

13. Windshield bracket

14. Bracket Holder

GB-2



- 15. Hook and loop fastener tape
- 16. Spare Power Fuse (2 Amp.).

INSTALLATION

A. GENERAL GUIDELINES

The following are some guidelines for mounting the detector :

- Mount the detector so that the receiving window/sensor (11) has an unobstructed view of the road ahead. The sensor is located at the opposite end from the control panel.
- The unit may be positioned within 25° of horizontal without significantly degrading performance.
- Do not mount directly behind windshield wipers.
- Do not mount behind a mirrored sunscreen, as it has a thin layer of aluminium on a plastic film which will block radar/laser signals.
- Mount the unit so that the control panel is plainly visible for the driver.
- Do not leave it in direct sunlight for long periods of time.

B. MOUNTING TYPES

We have provided 2 types of mounting methods.

•DASHBOARD MOUNTING (Drawing II)

The hook and loop fastener Velcro tape provided, may be used to mount your detector on a flat dashboard. The dashboard must be clean and dry for the fastener to adhere properly.

- Remove backing from the “LOOP(fuzzy)” piece and press firmly to the bottom of your unit.
- Clean dashboard with common rubbing alcohol to remove dirt and grease.
- Peel the backing from the hook side and press the unit into the desired position on the dashboard.

•WINDSHIELD MOUNTING (Drawing III)

- Insert the supplied suction cups and cushion into each slot and windshield bracket.
- Slide the windshield bracket assembly to bracket holder along with the groove on the bracket holder.
- Snap the bracket holder into the laser/radar detectors' track.
- Locate the bracket on a clean windshield and press firmly on each suction cup.
- You can modulate the angle. In that case first remove the detector from the windshield bracket.
- To remove the windshield bracket from the bracket holder, first detach the bracket holder from the

GB-3



radar/laser detector. And pulling up the small bar which locates at the centre of bracket holder and works as a locker, simply pull bracket out of slot.

FOR BEST PERFORMANCE WINDSHIELD MOUNTING IS RECOMMENDED!

C. POWER CONNECTION

The XT6000 is designed to operate from the normal 12Volt electrical system and must be used with a negative ground electrical system. Do not operate your XT6000 on positive ground electrical system. Consult your vehicle owners' manual if you are not certain of its polarity.

- After you position and mount detector, insert the DC power cable into the jack on detector's side.
- Remove vehicle cigar lighter from its socket and insert the other end of power cable into the lighter socket plug.
- For permanent installation, you may want to cut off the cigar lighter plug and wire the detector power cord to you vehicle's fuse box. When you do this, make certain you are wiring to a fused circuit of at least 1Amp. capacity.

HOW THE RADAR AND LASER WORK-GENERAL

A. HOW THE RADAR WORKS

The actual process involved in determining a vehicle's speed is basically a simple one. It involves directing a beam of microwave energy at an approaching target vehicle. A portion of this beam is reflected by the target and is received by the radar unit that originally transmitted the signal. The reflected signal is shifted in frequency by an amount proportional to the speed of the target vehicle. This phenomenon is known as the Doppler effect. The radar unit determines the target vehicle speed from the difference in frequency between the reflected signal and original signal.

B. RADAR & LASER FREQUENCIES

The most important frequencies that are used for radar traffic:

K-band:	24.15 GHz
Ka-band:	34.36 GHz

C. LASER DETECTION

Laser Speed Gun uses pulses of infrared laser light

GB-4



to measure speed of target by timing each pulses over time as it is reflected back to the gun.

D. LASER RANGE

The effective range of clocking distance by a laser gun is less than 250M. So, mount your laser detector as low as possible in the car.

OPERATION

A. SELF TEST

To turn the unit ON, turn the “Power/Volume”-switch on the left side of the detector toward the rear of the unit.

When placed in ON-position the unit will immediately perform a self-test. During this time the K/Ka/Laser tones will be activated in turn.

When self-test is completed the green LED will remain illuminated below “P” to show the set is “ON” status.

To turn the unit OFF, turn the “Power/Volume” switch into the opposite direction.

B. RADAR & LASER ALARMING

The detector will identify the band the radar signal

is being received on by separate audible tones for K ,Ka or LASER.

When your detector encounters a speed radar or LASER transmission it will respond with both audio and visual alarms.

The ‘1-2-3-4’ LED’s will indicate signal strength by increasing the number of LED’s that are lit: the leading LED will flash.

C. HIGHWAY MODE

Highway mode provides full audio alarms and maximum sensitivity for open road driving. It is automatically activated when power is applied or your unit is turned ON.

D. CITY MODE

There are many sources of false alarm signals near cities. The purpose of the city mode is to reduce sensitivity to eliminate most false sources so that the unit will not alarm for weak signals.

To access the city mode, simply press the ‘CITY’ button. The LED below (C) will illuminate. To turn OFF, press the button again.

GB-5



E. DARK MODE

If you are driving at night and you do not want the illumination of the LED array display to be visible, press the 'DARK' button. The audio alarm, however, will continue to function normally and the power light (P) will also be illuminated.

F. MUTE MODE

During a radar transmission when the audio alarm is sounding, you have the option to MUTE the alarm by pressing the 'MUTE' button momentarily. After leaving the area of the transmission source, the set will automatically de-mute after 10 seconds. You do not have to reset the unit.

G. HOW THE DETECTOR WARNS

! Starts to beep slowly, then increases in rate very rapidly

- FULL WARNING = Most likely police radar

! Beeps just once.

- EXERCISE CAUTION = Most likely a false source or could be pulsed radar

! Very fast beep rate instantly

- FULL WARNING = Radar close but has been suddenly switched on.

! Slow beep rate as you approach hill or bridge. Sharp increase in beep rate as you reach hill or bridge.

- FULL WARNING = Most likely police radar on other side of bridge hill or bridge.

! Short term, weak beeping, series of signals

- EXERCISE CAUTION = Most likely a false radar source.

MAINTENANCE

To keep your detector in good condition, follow these simple steps :

- Never leave the set on the visor, windshield or dashboard when you park your vehicle.
- Do not expose the unit to moisture.
- Always unplug the power cable or turn off the power when not in use.

GB-6



When your set has stopped entirely, we suggest you make the following checks :

- Is the power plug properly locked at the cigar lighter socket ?
- Is the power cord properly plugged in at both ends ?
- Is the fuse OK ?
- Is the cigar lighter socket clean and free from corrosion ?
- Is the Power/Volume switch on the left side of the set towards the rear of the unit ?

NOTE:

- Failing to rotate the top of the fuse holder down prior to rotating it will damage the fuse holder. Use of pliers to rotate the top may also cause damage.
- Illustration indicates direction that the fuse holder top must be rotated to reassemble.

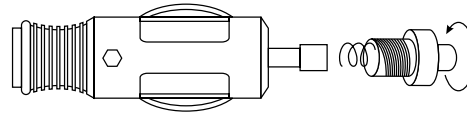

FUSE REPLACEMENT INSTRUCTIONS

Do not use any tools to change the fuse.

- Press the top of the fuse holder down and rotate it anti-clockwise approx. 30°. Lift the top straight up.
- Remove the fuse and replace if required by one of the same rating. The silver tip contains a spring which may fly off when disassembling. The fuse should be inserted before the spring.
- Place the top of the fuse-holder back on the body. Press down and rotate the top of the fuse holder clockwise approx. 30°.

GB-7



Drawing I

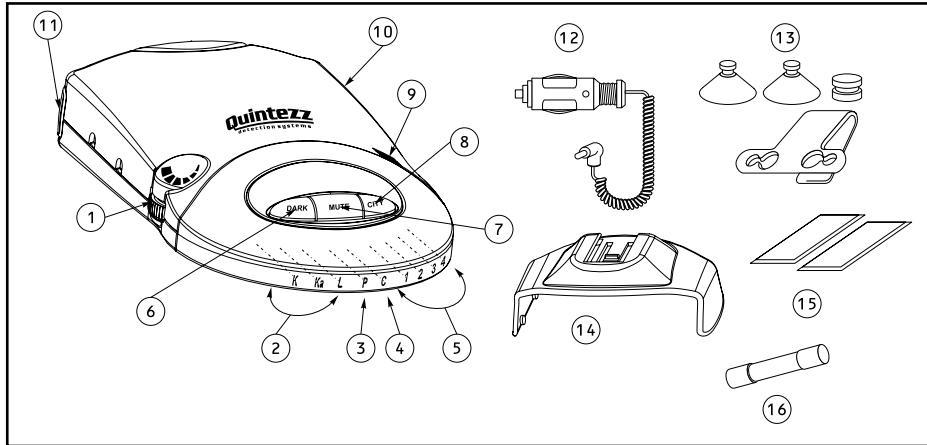

Drawing II

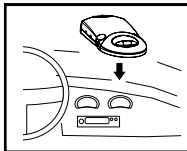

Drawing III

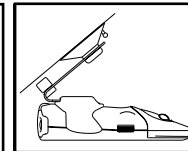
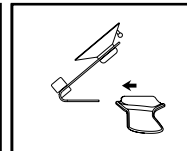
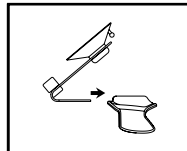
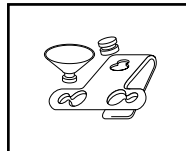



TABLE OF CONTENTS

INTRODUCTION	2
XT6000 FEATURES	2
INSTALLATION	3
A. GENERAL GUIDELINES	3
B. MOUNTING TYPES	3
C. POWER CONNECTION	4
HOW THE RADAR AND LASER WORK-GENERAL	4
A. HOW THE RADAR WORKS	4
B. RADAR & LASER FREQUENCIES	4
C. LASER DETECTION	4
D. LASER RANGE	5
OPERATION	5
A. SELF TEST	5
B. RADAR & LASER ALARMING	5
C. HIGHWAY MODE	5
D. CITY MODE	5
E. DARK MODE	6
F. MUTE MODE	6
G. HOW THE DETECTOR WARNS	6
MAINTENANCE	6
FUSE REPLACEMENT INSTRUCTIONS	7



**Designed and developed by M.D.B. nv/Belgium
- FAX : -32 - 3 - 664.88.90 -**

